

# Vacuum Transfer System TPF 30



Operate in dense phase

Capacity up to 4.000 liters/hour

Automatic level control

Easy disassembly

Food agreement

Available for ATEX Area



Easy disassembly

with toggle clamp



with triclamp collar

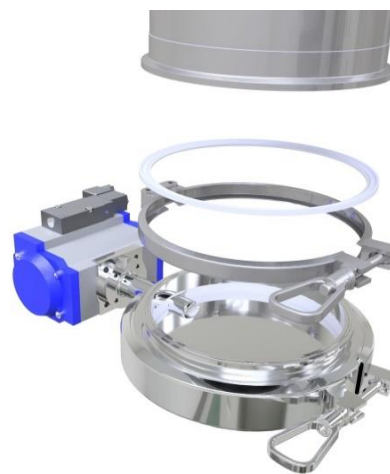

# Vacuum Transfer System TPF 30

Rep.	Item Name	Material
01	Blower solenoid	Aluminium
02	Blower tank	SS 304L
03	Compressed air coupling	Brass
04	Vacuum triclamp coupling SMS 38	SS 316L
05	Toggle clamp	SS 304L
06	Filter plate	SS 316L
07	Seal for filter plate	Silicone
08a	Standard Filter cartridge	Polyester
08b	ATEX filter cartridge	ePTFE
09	Cyclone body	SS 316L
10	Material inlet triclamp coupling SMS 51	SS 316L
11	High level probe	N/A
12	Level probe housing	POM
13	Triclamp collar SMS 200	SS 316L
14	Triclamp seal SMS 200	Silicone
15	Triclamp butterfly valve SMS 200	SS 316L

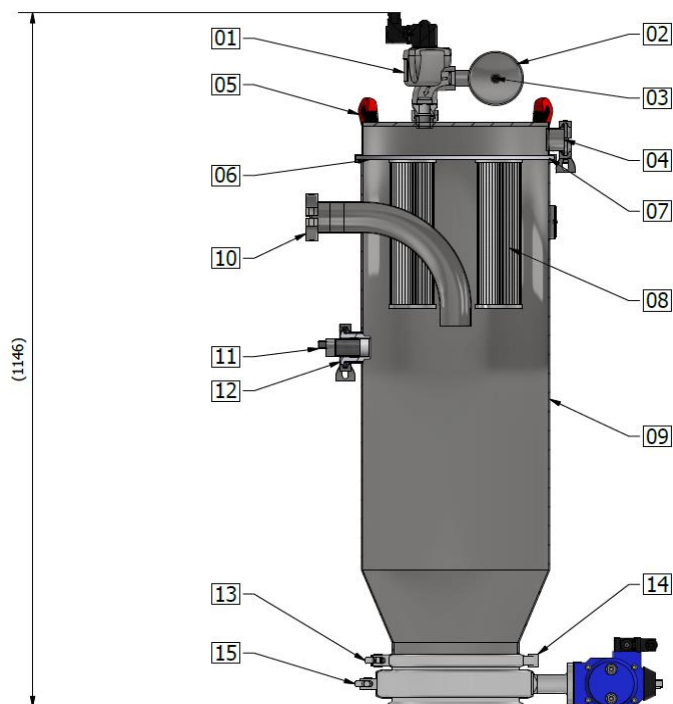

Cyclone weight: 55 kg

## Options

Item Name	Material
Vibro aerator	SS 316L
Support frame	SS 304L
Pneumatic vibrator	

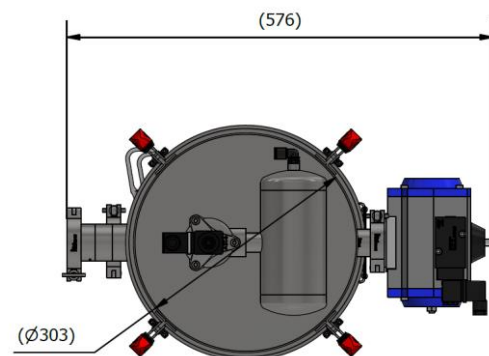

Item Name	Material
Control panel with PLC	Epoxy
Control panel with PLC	St Steel
Electrical vacuum pump 80 à 160 m <sup>3</sup> /h	

Item Name	Material
Automatic flushing line	SS 316L
Antistatic flexible hose	PVC or PUR
Suction device	SS 316L



**TECHNIlab**<sup>®</sup>

30 bis, rue du bois chaland, CE 2948 - 91029 EVRY Cedex France

Tél : + 33 (0) 1 60 86 96 48 - Fax : + 33 (0) 1 60 86 90 01

[www.technilab.fr](http://www.technilab.fr)