

# Vacuum Transfer System TPF 30 with flap



Operate in dense phase

Capacity up to 4.000 liters/hour

Automatic level control

Easy disassembly

Food agreement

Available for ATEX Area



Easy disassembly

with toggle clamp

Quick-locking hose clamp



# Vacuum Transfer system TPF 30 with flap

Rep.	Item name	Material
01	Blower solenoid	Aluminium
02	Blower tank	SS 304L
03	Compressed air coupling	brass
04	Vacuum triclamp coupling SMS 38	SS 316L
05	Toggle clamp	SS 304L
06	Filter plate	SS 316L
07	Seal for filter plate	Silicone
08a	Standard filter cartridge	Polyester
08b	ATEX filter cartridge	ePTFE
09	Cyclone body	SS 316L
10	Material inlet triclamp coupling SMS 51	SS 316L
11	High level probe	N/A
12	Level probe housing	POM
13	Seal	Silicone
14	Jacob quick locking hose clamp	SS 304L
15	Discharging flap	SS 316L

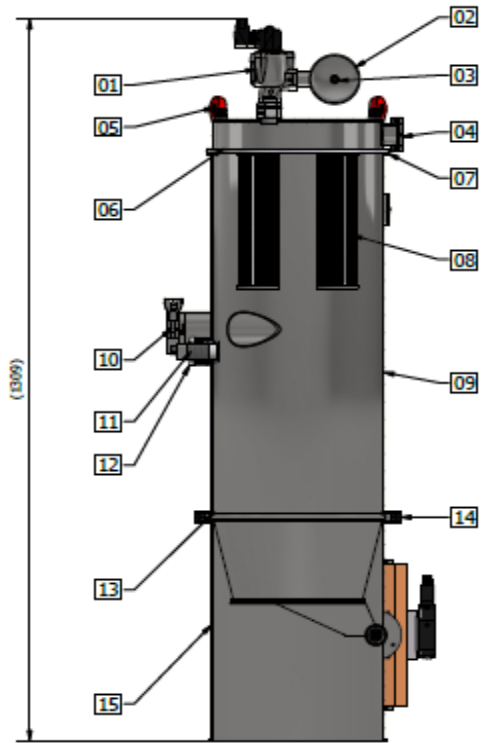

Cyclone weight : 45 kg

## Options

Item Name	Material
Vibro aerators	SS 316L
Support frame	SS 304L
Pneumatic vibrator	

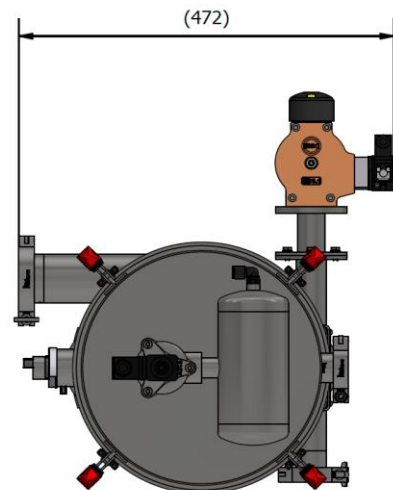
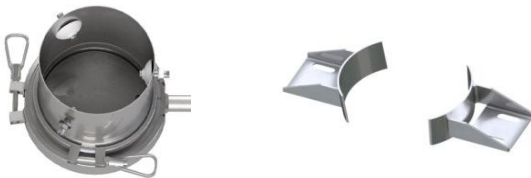

Item Name	Material
Control box with PLC	Epoxy
Control box with PLC	St. Steel
Electrical vacuum pump 100 - 200 m <sup>3</sup> /h	



Item Name	Material
Automatic flushing line	SS 316L
Antistatic flexible hose	PVC or PUR
Suction device	SS 316L



# TECHNIlab®

30 bis, rue du bois chaland, CE 2948 - 91029 EVRY Cedex France

Tél : + 33 (0) 1 60 86 96 48 - Fax : + 33 (0) 1 60 86 90 01

[www.technilab.fr](http://www.technilab.fr)