

Transporteur Pneumatique TPC 200



Fonctionne en phase dense

Débit jusqu'à 12 000 litres/heure

Régulation de niveau

Démontage facile

Sans zone de rétention

Destiné aux poudres difficiles

Disponible pour zones ATEX



Version

Clamp

Boulon basculant

Bride



Transporteur Pneumatique TPC 200

Rep.	Désignation	Matière
01	Electrovanne de décolmatage	Laiton
02	Réservoir de décolmatage	Inox 304L
03	Raccord rapide air comprimé tube 6x8	Laiton
04	Raccord triclamp Vide SMS 51	Inox 316L
05	Collier de serrage Profil V	Inox 304L
06	Plateau Porte Filtre	Inox 316L
07	Joint de plateau porte filtre	Silicone
08a	Elément filtrant	Polyester
08b	Elément filtrant ATEX	ePTFE
09	Corps de cyclone clamp SMS 250	Inox 316L
10	Raccord triclamp Matière SMS 63	Inox 316L
11	Détecteur capacitif	Aluminium
12	Doigt de gant	PTFE
13	Collier triclamp SMS 250	Inox 316L
14	Joint ferrule clamp SMS 250	Silicone
15	Vanne papillon triclamp SMS 250	Inox 316L

Masse du cyclone : 55 kg

Options

Désignation	Matière
vibroaérateur	Inox 316L
Gousset de supportage	Inox 304L
Vibreux pneumatique	

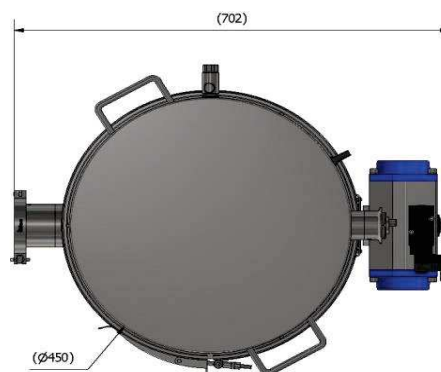
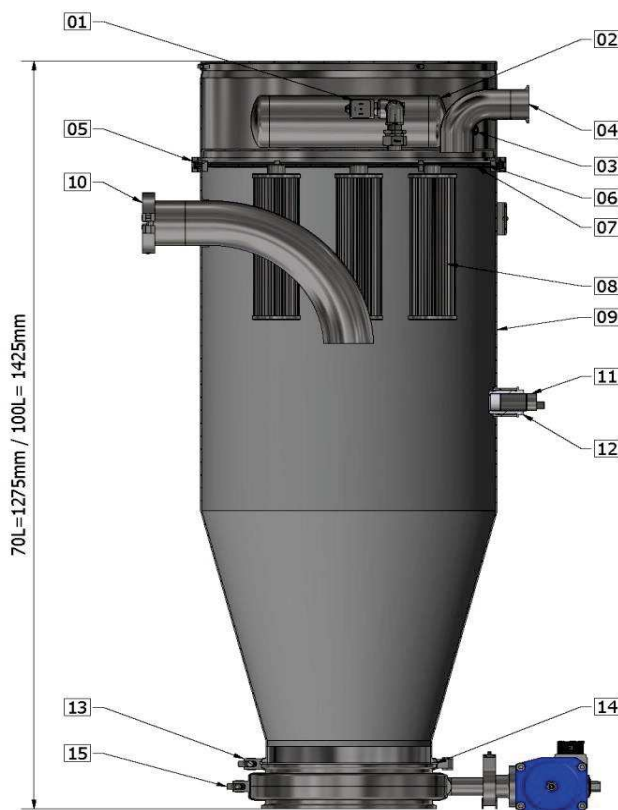

Désignation	Matière
Coffret de pilotage avec automate	Acier
Coffret de pilotage avec automate	Inox
Pompe à vide 200 à 500 m ³ /h	



Désignation	Matière
Canne d'aspiration	Inox 316L
Vide de ligne automatique	Inox 316L
Adaptateur d'aspiration	Inox 316L



TECHNIlab®

30 bis, rue du bois chaland, CE 2948 - 91029 EVRY Cedex France

Tél : + 33 (0) 1 60 86 96 48 - Fax : + 33 (0) 1 60 86 90 01

www.technilab.fr